

"DEZVOLTARE ZONA MIXTA COMERT, SERVICII, FUNCTIUNI ADMINISTRATIVE SI LOCUIRE COLECTIVA IN REGIM DE INALTIME S+P+6E+ET"

# plan urbanistic zonal

U.T.R.1  
SUBZONA MIXTA COMERT, SERVICII,  
FUNCTIUNI ADMINISTRATIVE SI BIROURI  
INDICI PROPUZI  
P.O.T. 70%  
regim de de inaltime S+P+6E+ET  
Spatii verzi min. 20%  
Hmax=32.00m

U.T.R.2  
SUBZONA MIXTA COMERT, SERVICII  
SI LOCUIRE COLECTIVA  
INDICI PROPUZI  
P.O.T. 50%  
regim de de inaltime S+P+6E+ET  
Spatii verzi min. 20%  
Hmax=30.00m

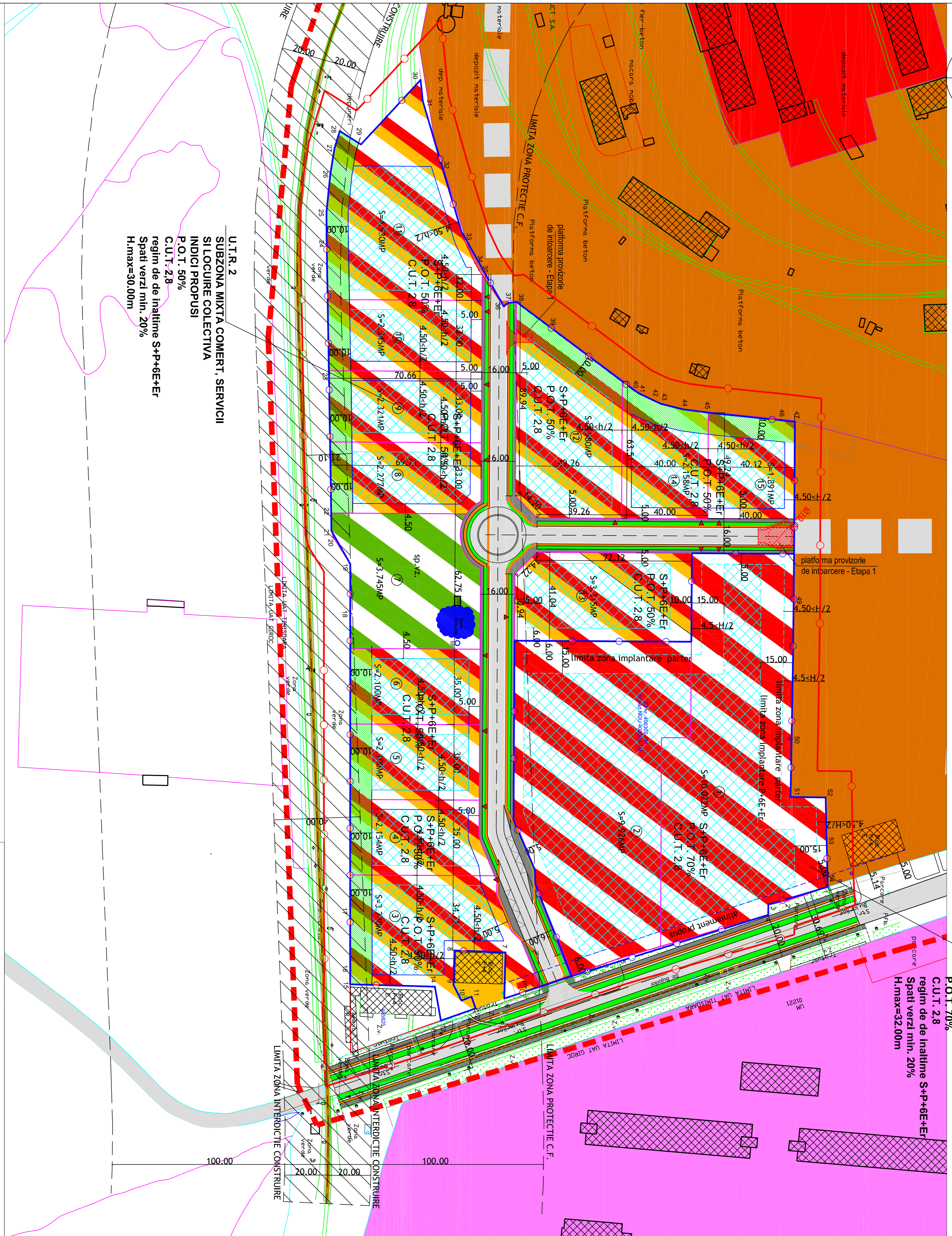

PTT - 16 m  
scara 1:100

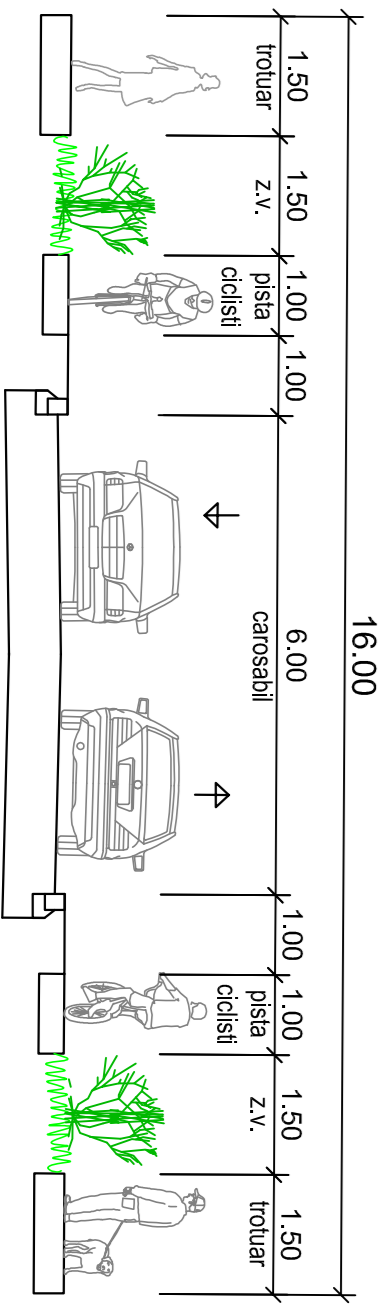

- ### LEGENDA
- #### LIMITE SI DELIMITARI
- Limite teren conform C.F.
  - Limite teren ce face obiectul PUZ
  - Limite zona studziata
  - Limite UTR
  - Limite intravilan
  - Limite parcele propuse
  - Limite zona implantare a cladirilor
  - Limite zona implantare a cladirilor in regim cuplat(comasare parcele)
- #### SIMBOLURI
- Cladiri existente
  - Cf.nr. 406302
  - Nr. Cf parcele existente
  - S=64,488mp
  - spatii verzi de aliment
  - platforma provizorie de incalzire - Etapa 1
  - acces propus

- #### U.T.R.1 - SUBZONA MIXTA COMERT, SERVICII, FUNCTIUNI ADMINISTRATIVE SI BIROURI PROPUZA
- SAM - Subzona mixta comert, servicii, functiuni administrative si birouri propusa
  - Scc - Subzona cai de comunicatie rutiera
  - zona spatii verzi amenajate in cadrul parcelelor
- #### U.T.R.2
- #### SUBZONA MIXTA COMERT, SERVICII SI LOCUIRE COLECTIVA PROPUZA
- SzL - Subzona mixta comert, servicii si locuire colectiva propusa
  - zona spatii verzi amenajate in cadrul parcelelor
  - SzV - Subzona spatii verzi amenajate propusa

- #### U.T.R.3
- #### SUBZONA LOCUIRE COLECTIVA EXISTENTA
- subzona locuire colectiva existenta
  - zona spatii verzi amenajate in cadrul parcelelor
  - zona implantare a cladirilor
  - subzona industriale, productie cu caracter nepoluant existenta
  - subzona servicii birouri
  - activitati economice cu caracter teritar existenta
  - subzona locuire colectiva existenta
  - subzona destinate specialta MAPN existenta

### BILANT TERITORIAL

SUPRAFATA TEREN	SITUATIA EXISTENTIA	SITUATIA PROPUZA
Szi- subzona industriale Cladiri platforme, parcuri, alei spatii verzi amenajate	64.698,00 mp 11.242 (17,37%) 53.456 (82,63%) 0 (0,00%)	-
UTR 1 - Subzona mixta comert, servicii, functiuni administrative si birouri SzM - subzona mixta comert, servicii, functiuni administrative si birouri cladiri platforme, parcuri SzV - spatii verzi amenajate in cadrul parcelor	19.806,6 mp 13.864mp (70%) 1.980mp (10%) 3.962mp (20%)	30,61%
UTR 2 - Subzona mixta comert, serviciilor si locuire colectiva Sec- subzona cai de comunicatie rutiera SzL - subzona mixta comert, servicii, si locuire colectiva cladiri platforme, parcuri, alei, locuri de joaca spatii verzi amenajate in cadrul parcelor SzV - subzona spatii verzi amenajate spatii verzi independente	44.892mp 7.828mp 17,43% 33.319mp 75,40% 16.659mp 9.996 mp 6.664mp 3.745 23,04%	69,39%
<b>TOTAL</b>	<b>64.698,00</b>	<b>100,00%</b>

PROIECTANT GENERAL: S.C. TB DEZVOLTARE SERV S.R.L. CUI3988289 J3535312/16 tel:+40756060639 PROIECTANT SPECI: CUI39295451 J35202/15 TEL:+40742026355		Denumire proiect: P.U.Z. Modernizare UTR "Subzona mixta comert, servicii, functiuni administrative si birouri" Beneficier: SEC. COMUNA ROSCOTINELE SA Str. Bujoiilor nr.150, Timisoara, Jud. Timis		Nr. proiect: 109/2019	
Ser proiect: Proiectant: Desenat: Verificat:	An.Lucian Stancu An.Lucian Stancu An.Sorin Stigeti An.Lucian Stancu	Scara: Data: Reglementi urbanistice	Denumire planșă: P.U.Z.	Nr. planșă: 109/005	